

# SALUS Circulating Pump

Model No:- MP100

**The Salus Circulating Pump offers the ultimate choice for the installer.**

**The MP100 offers outstanding performance and high reliability to the user. Suitable for all domestic circumstances. It is designed for a quiet and long reliable life. A three speed motor enables precise pump to system matching, thereby reducing hydraulic noise to a minimum.**

The MP100 comes as standard with a 5 year guarantee



## Dimensions

Length 130mm

Height 120mm

Width; 120mm

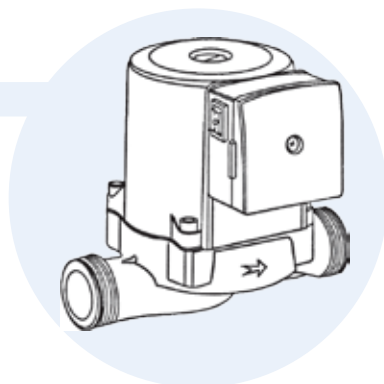

## features

- Standard port to port length of 130mm
- Quick fit electrical connectors for easy wiring
- 3 Speed selection
- 5 Year Guarantee

Web: [www.salus-tech.com](http://www.salus-tech.com) | Email: [sales@salus-tech.com](mailto:sales@salus-tech.com)

Sales +44 (0) 1226 323961 Technical +44 (0) 1226 240588